

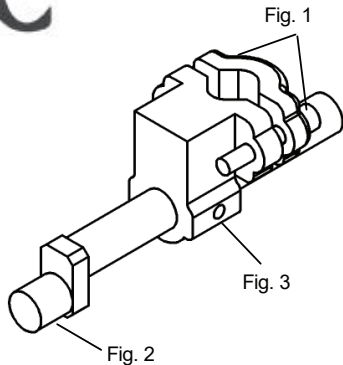

## A SERIES INSTALLATION & ADJUSTMENT INSTRUCTIONS



1. **CAUTION:** Be sure to disconnect the saw from the power supply before installing or making any adjustments to the band saw guides or mounts.
2. The A series brackets are for square, round or hexagonal guide post attachment.
3. Loosen the screws on the locking plate (Fig. 1) to open the clamp to the desired diameter to fit your post size. Retighten the clamp evenly so that it is secured at the end of the post. In-adequate tension may cause your mount and guides to wander and cause potential hazard to operator. Due to machine vibration it is advisable to check and retighten these during regular maintenance or use a thread locking agent to secure the bolt.
4. Rotate stud to align the guide with respect to the blade. Mount guide in end (Fig. 2) Blade should be centered on mounting stud hole in guide assembly. Make sure guides are parallel with blade and perpendicular with band saw for proper performance.
5. When the desired alignment and spacing has been set the stud should be locked into place with the set screw on the side of the A series mount (Fig. 3).

CARTER PRODUCTS COMPANY

2871 Northridge Drive NW - Grand Rapids, MI 49544 - Toll Free:888.622.7837

[www.carterproducts.com](http://www.carterproducts.com)